



# Tackle Your Toughest Conditions



Move More Payload ◀ Faster Dump Cycle ▶ Haul with Standard License

800-779-8099 or 712-546-4409 • [sales@sidedump.com](mailto:sales@sidedump.com) • [sidedump.com](http://sidedump.com)



**RE-ENGINEERED TO BE OUR  
TOUGHEST TRAILER YET**



**Hydraulic Front Hitch**  
2.5x stronger shaft with linear shock absorber for a better ride



**Heavy-duty Hinges**  
Increase longevity with all new heavy-duty self-aligning tub hinges



**Re-engineered Frame**  
New G-channel frame improves weight-to-strength rating



**Hydraulic Landing Leg**  
Easily adjust to different tractor heights



**Extension Option**  
Double your load capacity with super high volume extensions



**Liner Option**  
Prevent materials from sticking with bolt-on flop-out liner

**Train and Tandem**

Run single 30-ton units or hook tandem or triple combinations to move more material



## HAUL MORE: SAFER, FASTER & EASIER

- Faster load time, faster dump cycle
- Lower maintenance costs increase profitability
- Stockpile or windrow for strategic dumping
- Minimal training to operate

## INDUSTRIES



### Agriculture

- High volume, low load height
- Watertight; no leaks for wet loads
- All-terrain flotation tires



### Construction

- Haul dirt, rock, riprap and other abrasive materials
- Configuration flexibility for tandem or trains
- Dump to either side on uneven ground



### Off-road Site Prep

- Haul more dirt at a lower cost
- Lower maintenance costs than traditional equipment
- No special license required



### Snow Removal

- Flop-out liner prevents snow from sticking
- Even distribution for stable dump
- No backing up, better sightlines



To learn more about SmithCo,  
visit our website: [sidedump.com](http://sidedump.com)



## CP30 Specifications

<b>NEW</b>	<b>Hitch</b>	Standard 2" drawbar pin, scraper-type adapters available
<b>NEW</b>	<b>Tongue</b>	Hydraulically adjustable to flip between lead & pup
	<b>Landing Gear</b>	Hydraulic, high clearance
	<b>Pushblock</b>	Standard, rear hitch available
	<b>Safety Chains</b>	1/2" Safety chains with safety hooks
	<b>Tub Construction</b>	1/4" Thick, AR 450 (or equivalent) round floor style tub
<b>NEW</b>	<b>Frame Construction</b>	80/100 KSI, G-Frame, eliminates need for counterweights
	<b>Cylinders</b>	3500 PSI, 5" Bore
<b>NEW</b>	<b>Hinges</b>	Self-aligning, spherical bearing type (greaseable)
	<b>Suspension</b>	90K Walking beam
	<b>Axles</b>	30K Capacity
	<b>Hubs</b>	10 Hole, hub piloted
	<b>Drums</b>	Outboard mount, cast steel
	<b>Brakes</b>	None, hydraulic or air optional
	<b>Wheels</b>	Tubeless, steel disc
	<b>Tires</b>	Heavy-duty flotation tires
	<b>Lights</b>	12 Volt LED with sealed harness
	<b>Paint</b>	Polyurethane, any combination of gray, white or black Special colors available upon request
	<b>Min. Tractor Hydraulic Reqs.</b>	25-30 GPM, 2,600-2,800 PSI, 10 gallon reservoir
	<b>Net Payload Rating</b>	30 Tons



## Capacity

<b>Waterfull</b>	15.3 cu yd
<b>Heaped</b>	22 cu yd
<b>NEW</b> <b>Extended CHNL Heaped</b>	49 cu yd (optional bolt on extension)

## Dimensions

<b>Frame Length</b>	30' 9"
<b>Tub Length</b>	21'
<b>Width</b>	10' (120")
<b>Height</b>	8' 4" (100")

## CP30 Side View

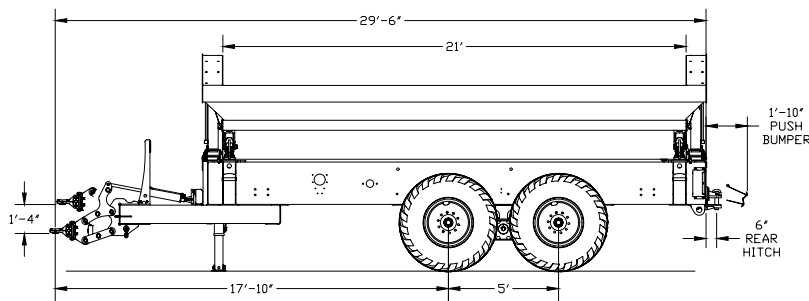

## CP30 Rear View

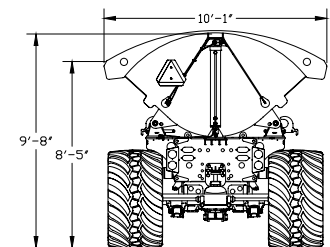

## CP30 CHNL Side View

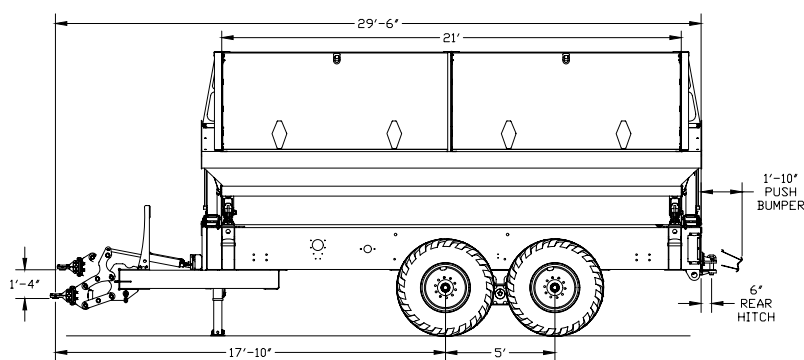

## CP30 CHNL Rear View

