

REVISIONS			
DATE	SYM.	DESCRIPTION	AUTHORITY

TRAILER WITH 1/4" FLOOR, 1/4" SIDES TUB
 RIDEWELL RW260 AIR RIDE SUSPENSIONS, AIR LIFT 1ST & 4TH AXLES
 385/65 R22.5 SUPER SINGLE TIRES ON ALUMINUM WHEELS AXLES 1-3, 295/75 R 22.5 SINGLE TIRES ON 4TH AXLE
 ELECTRIC MESH TARP

GROSS VEHICLE WEIGHT	99,710
TRAILER	20,700
AIR LIFT TAG	N/A
TRACTOR (EST.)	22,300
NET PAYLOAD	56,710

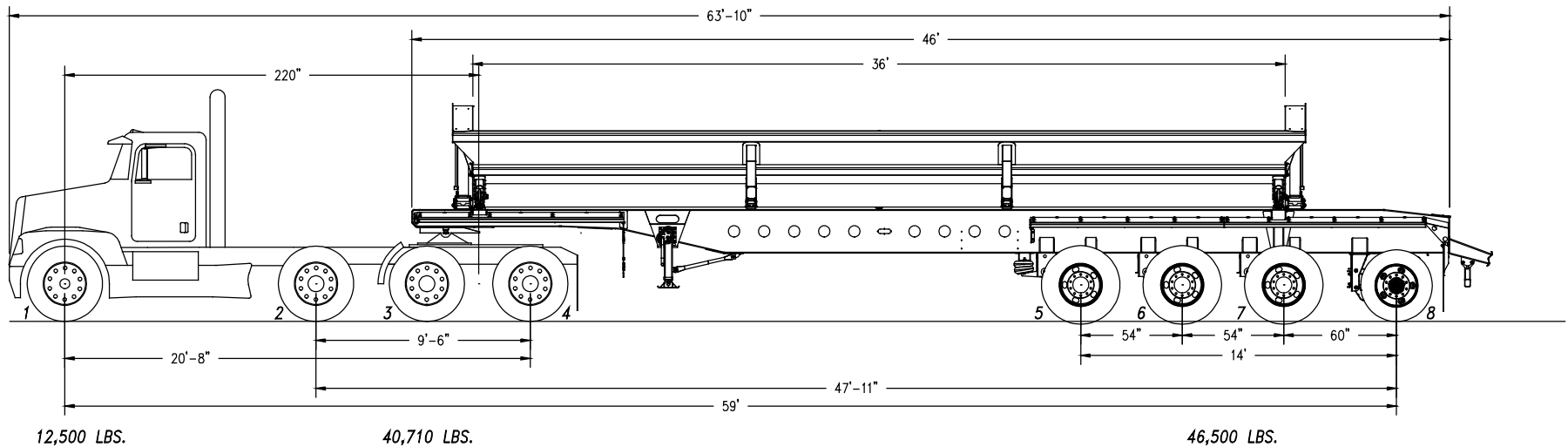

BRIDGE LAW				
BRIDGE	AXLES	DISTANCE	DOT ALLOWED WEIGHT	ACTUAL WEIGHT
1-4	4	21'	56,000	53,210
1-8	8	59'	99,710	99,710
2-4	3	10'	43,500	40,710
2-8	7	48'	88,000	87,210
5-8	4	14'	51,330	46,500

CONTROLLING CRITERIA

CHANGING TRACTOR LENGTH AND/OR WEIGHT CAN EFFECT THE BRIDGE LAW WEIGHTS AND THEREFORE THE NET PAYLOAD.

THE ABOVE IS SMITHCO'S UNDERSTANDING OF THE BRIDGE LAW AND WEIGHT LAW FOR THE GIVEN STATE. IT IS THE CUSTOMERS RESPONSIBILITY TO VERIFY IT.

ITEM	QTY	PART NUMBER	DESCRIPTION	MAT'L	WT
<small>This drawing and the design it covers are the property of SMITHCO. They are loaned merely and on the borrower's expressed agreement that they will not be reproduced copied loaned exhibited nor used except in the limited way and private use permitted by any written consent given by the lender to borrower.</small>					
DRAWN BY: J. VERROS				TITLE: NET PAYLOAD using SMITHCO SIDE DUMP TRAILER	
CHECKED BY: --					
DO NOT SCALE PRINT		UNLESS OTHERWISE SPECIFIED: ±1/16		SCALE: 1/80	
DIMENSIONS ARE IN INCHES		TOLERANCES ON:		DATE: 10/23/2019	
3 PLACE DEC.		2 PLACE DEC.		ANGLES	
--		--		±0°30'	
SHEET 1 OF 1		REV.		MONTANA - SH#74	

MONTANA - SH#74